

GMAX32152

Evaluation Kit

General Description

Gpixel's evaluation platform supports CoaXPress 2.0 or USB3 Interface, is ideal for an easy and accurate evaluation of the GMAX32152 CMOS sensor. Its form factor, the GenICam compatibility and external triggering options provide flexible setup options in both lab and industrial environments. The high-speed CoaXPress /USB3 interface ensures a smooth, real-time imaging experience.

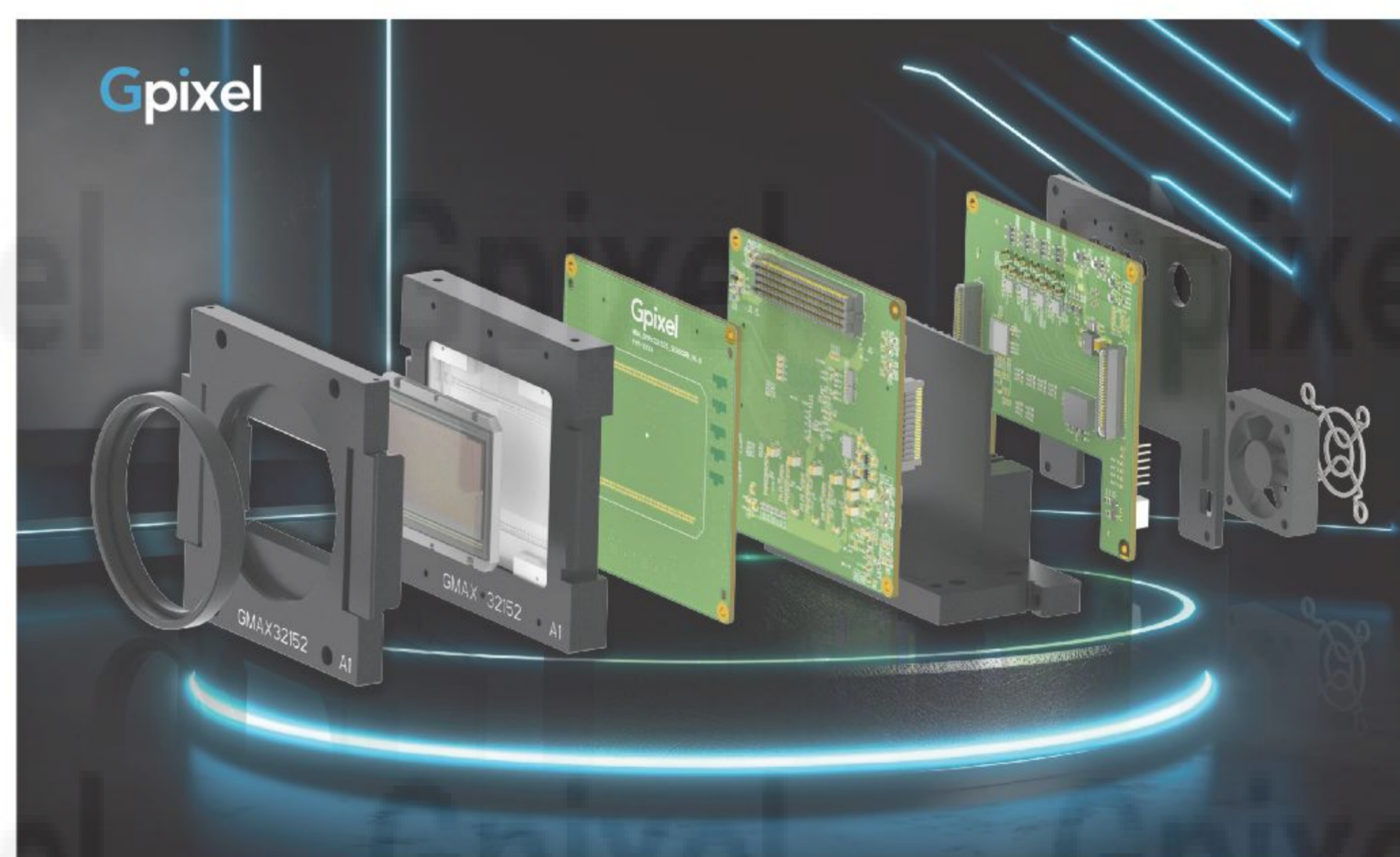

Key Features

- CoaXPress 2.0 Interface /USB3 Interface
- Raw Image Output
- Normal, Binned or Windowed Readout
- GenICam Compatible
- User-friendly Form Factor
- M72-mount

Specifications

Item	Description
Sensor	GMAX32152
Output Interface	CoaXPress 2.0/USB3
Resolution (H x V)	16556 x 9200
Frame Rates	16fps@CoaXPress 2.0 Interface 1.2fps@USB3 Interface
Exposure Time	19μs ~ 49.9s
Pixel Bit Depth	12-bit
Trigger Mode	External / Free Running
Lens Mount	M72-mount
Power Supply	10V~25V
Power Consumption	Typical 19.9W@12V DC @CoaXPress 2.0 Typical 12.1W@12V DC @USB3
Operating Temperature	0-50°C

Ordering Information

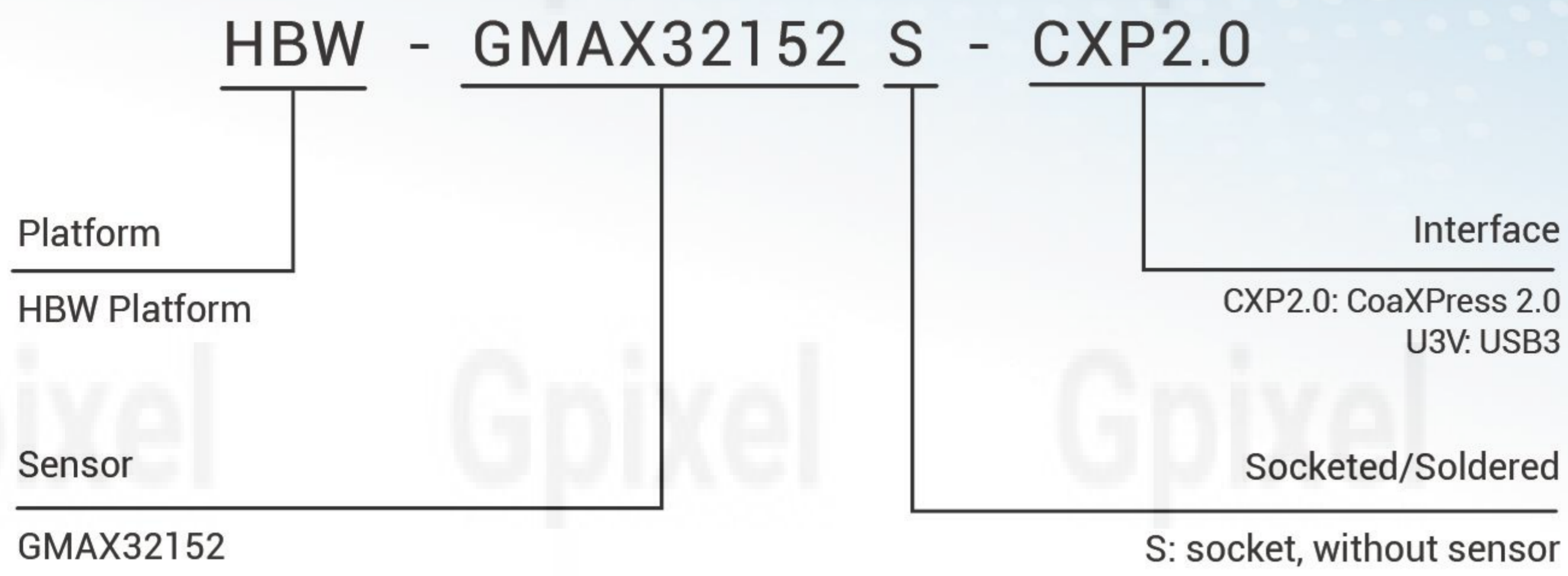

Evaluation Kit Includes

- Evaluation module
- Power adapter
- Power Cable with DC plug and trigger
- DC Plug adapter 2.1mm to 2.5mm
- Extension ring M72 to M72-7.55mm
- USB Cable Type-A to Micro-B (only USB3 Interface)

Note: 1.A CXP2.0 frame grabber and four CXP cables are required to use this evaluation kit.
2.The sensor is not included in evaluation module.

Mechanical Drawing

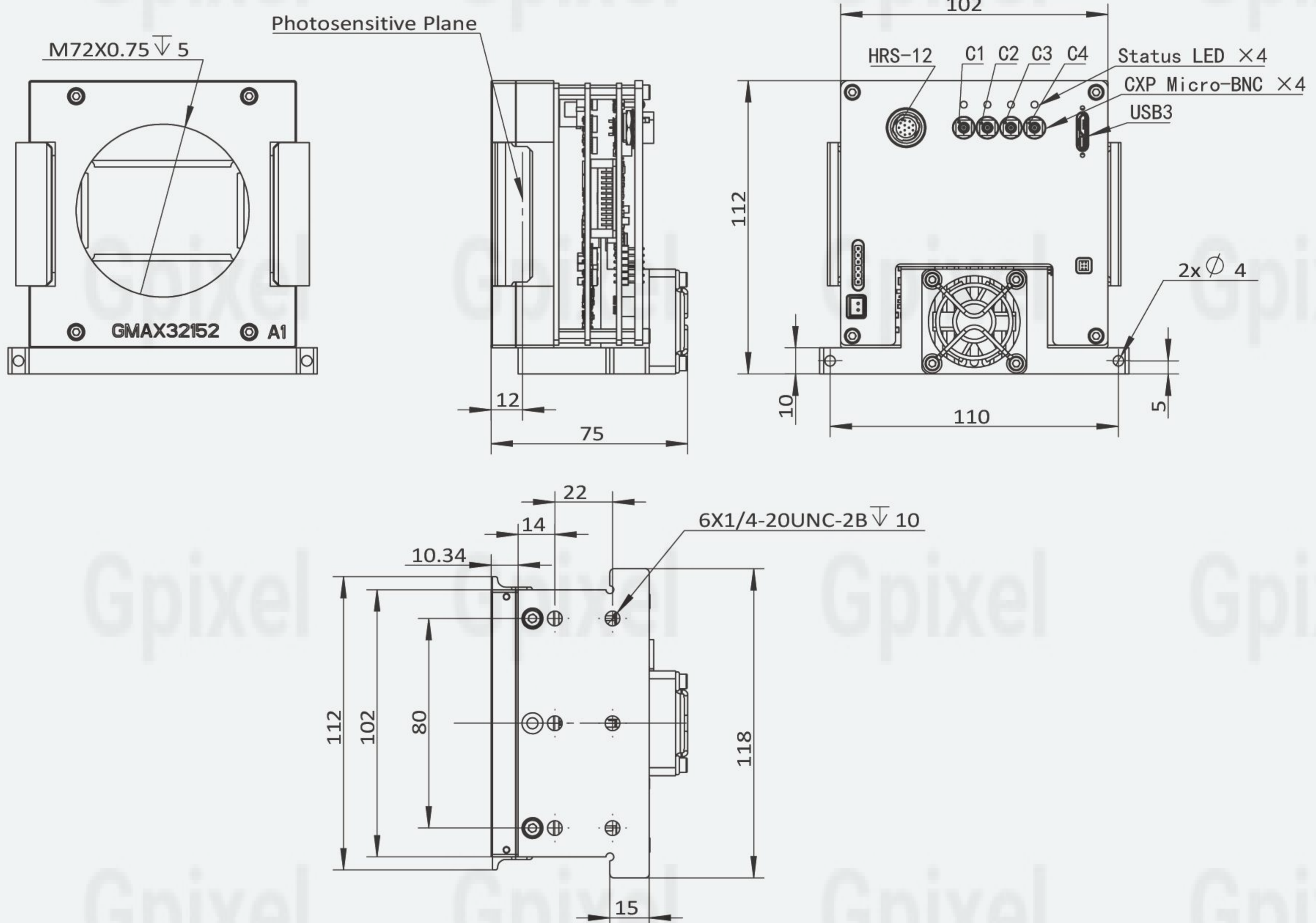

Note: HBW-GMAX32152S-CXP2.0 only has CXP Micro-BNC connector,
HBW-GMAX32152S-U3V only has USB3 Micro-B connector.

Contact Gpixel HQ

Add: Building #5, Optoelectronic Information Industrial Park, #7691 Ziyou Road, Changchun, Jilin, China.

Tel: +86-0431-85077785

Email: info@gpixel.com

Website: www.gpixel.com

Revision 20240208

